

**Modular Cooking Range Line
EVO900 4-Burner Gas Range 10kW
(Cast Iron Grids) on Gas Oven**

ITEM # _____

MODEL # _____

NAME # _____

SIS # _____

AIA # _____

**Modular Cooking Range Line****EVO900 4-Burner Gas Range 10kW
(Cast Iron Grids) on Gas Oven**

392031 (Z9GCGH4CGM)

4-burner (10 kW each) gas
range on gas oven - cast iron
grids**Short Form Specification****Item No.** _____

To be installed on stainless steel feet with height adjustment up to 50 mm. High efficiency flower flame burners with continuous power regulation and optimized combustion. Flame failure device as standard on burners to protect against accidental extinguishing. Oven chamber with 3 levels of runners to accommodate 2/1 GN shelves (2 steam pans). Ribbed, cast-iron oven base plate. Exterior panels of unit in stainless steel with Scotch Brite finish. Pan supports in heavy duty cast iron. Extra strength work top in heavy duty 2 mm stainless steel. Right-angled side edges to allow flush-fitting junction between units.

Main Features

- Gas appliance supplied for use with natural or LPG gas, conversion jets supplied as standard.
- Burners with optimized combustion.
- Flame failure device on each burner protects against gas leakage when accidental extinguishing of the flame occurs.
- Protected pilot light.
- The special design of the control knob system guarantees against water infiltration.
- IPX5 water protection.
- Large sized pan support in cast iron with long center fins to allow the use of the largest down to the smallest pans.
- Unit to be mounted on open base cupboards, bridging supports or cantilever systems.
- The four 10 kW high efficiency burners are available in two different sizes to suit high performing cooking requirements of the most demanding customers:
 - 60 mm burners with continuous power regulation from 1,5 to 6 kW
 - 100 mm burners with continuous power regulation from 2.2 kW to 10 kW

Construction

- Unit is 930 mm deep to give a larger working surface area.
- All exterior panels in Stainless Steel with Scotch Brite finishing.
- AISI 304 stainless steel worktop, 2mm thick.
- Model has right-angled side edges to allow flush fitting joints between units, eliminating gaps and possible dirt traps.

APPROVAL: _____

Included Accessories

- 1 of GN2/1 chrome grid for static oven PNC 164250

Optional Accessories

- GN2/1 chrome grid for static oven PNC 164250
- Junction sealing kit PNC 206086
- Draught diverter, 150 mm diameter PNC 206132
- Matching ring for flue condenser, 150 mm diameter PNC 206133
- 4 wheels, 2 swivelling with brake (EVO700/900). It is mandatory to install with base supports for feet/wheels. PNC 206135
- Flanged feet kit PNC 206136
- Frontal kicking strip for concrete installation, 400 mm PNC 206147
- Frontal kicking strip for concrete installation, 800 mm PNC 206148
- Frontal kicking strip for concrete installation, 1000 mm PNC 206150
- Frontal kicking strip for concrete installation, 1200 mm PNC 206151
- Frontal kicking strip for concrete installation, 1600 mm PNC 206152
- Pair of side kicking strips (concrete installation) PNC 206157
- Side handrail for right/left hand PNC 206165
- Frontal handrail 400 mm PNC 206166
- Frontal handrail 800 mm PNC 206167
- Single burner radiant plate for pan support PNC 206170
- Single burner smooth plate for direct cooking - fits frontal burners only PNC 206171
- Single burner ribbed plate for direct cooking - fits frontal burners only PNC 206172
- Frontal kicking strip, 800 mm PNC 206176
- Frontal kicking strip, 1000 mm PNC 206177
- Frontal kicking strip, 1200 mm PNC 206178
- Frontal kicking strip, 1600 mm PNC 206179
- Pair of side kicking strips PNC 206180
- 2 panels for service duct (single installation) PNC 206181
- Large handrail (portioning shelf) 400 mm PNC 206185
- Large handrail (portioning shelf) 800 mm PNC 206186
- Frontal handrail 1200 mm PNC 206191
- Frontal handrail 1600 mm PNC 206192
- 2 panels for service duct (back to back installation) PNC 206202
- Pair of cast iron grids for gas ranges and boiling tops PNC 206208
- 4 feet for concrete installation (not for 900 line freestanding grill) PNC 206210
- Flue condenser for 1 module, 150 mm diameter PNC 206246
- Water column with swivel arm (water column extension not included) PNC 206289
- Water column extension PNC 206290
- Stainless steel grid for 2 burners PNC 206298

- Chimney upstand, 800 mm PNC 206304
- 2 side covering panels, height 700 mm, depth 900 mm PNC 206335
- Wok pan support for open burners (EVO700/900) PNC 206363
- Base support for feet or wheels - 800mm (EVO700/900) PNC 206367
- Kit town gas nozzles (G150) for EVO900 gas ranges on gas oven PNC 206385
- Chimney grid net, 400mm PNC 206400
- Pressure regulator for gas units PNC 927225

Modular Cooking Range Line EVO900 4-Burner Gas Range 10kW (Cast Iron Grids) on Gas Oven

Front

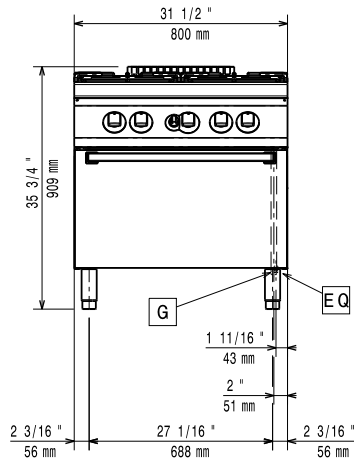

Top

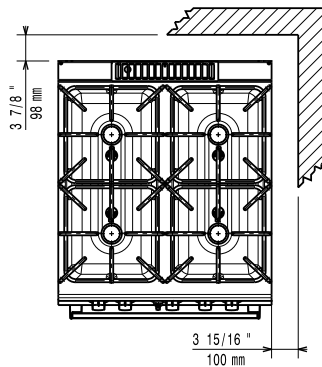

EQ = Equipotential screw
G = Gas connection

Side

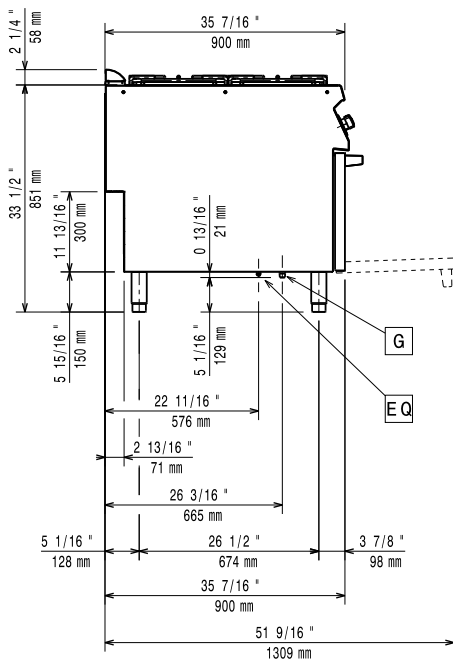

Gas

Gas Power:	392031 (Z9GCGH4CGM)	165337 Btu/hr (48.5 kW)
Gas Type Option:		LPG; Natural Gas
Gas Inlet:		1/2"
Natural gas - Pressure:		7" w.c. (17.4 mbar)
LPG Gas Pressure:		11" w.c. (27.7 mbar)

Key Information:

Front Burners Power:	10 - 10 kW
Back Burners Power:	10 - 10 kW
Back Burners Dimension - mm	Ø 100 Ø 100
Front Burners Dimension - mm	Ø 100 Ø 100
Oven working Temperature:	120 °C MIN; 280 °C MAX
Oven Cavity Dimensions (width):	575 mm
Oven Cavity Dimensions (height):	300 mm
Oven Cavity Dimensions (depth):	700 mm
Net weight:	155 kg
Shipping weight:	140 kg
Shipping height:	1090 mm
Shipping width:	1020 mm
Shipping depth:	860 mm
Shipping volume:	0.96 m ³

If appliance is set up or next to or against temperature sensitive furniture or similar, a safety gap of approximately 150 mm should be maintained or some form of heat insulation fitted.