

# Washer extractors

## W4240H

### Features and benefits

- **Clarus Control® with:**
  - Fully programmable microprocessor
  - All relevant wash parameters can be programmed
  - Programming from key pad or downloading via memory card
- High extraction force for efficient dewatering
- Extremely low water and energy consumption – see table below
- Four compartment soap box for manual dosing of powder or liquid detergent
- Stainless steel front panel and grey side panels
- Large door opening for easy loading/unloading
- Low noise level, for pleasant working environment
- SuperBalance™ guarantees the correct extraction force

### Main options

- IS – Integrated Saving
- Stainless steel side panel
- Dual drain valves for water re-use



Images shown are a representation of the product only and variations may occur.

Main specifications			W4240H	
Max. capacity		kg/lb	27/60	
Drum, volume		litre	240	
	diameter	ø mm	795	
Extraction		rpm	890	
G-factor			350	
Heating alternatives, 230/400V	electricity	kW	19.1 / 19.8 / 23.0	
	steam		x	
	non-heated		x	
<b>Consumption data "Normal 60°C" * (3G01)</b>			El	Steam
Total time		min	46	**
Water consumption (cold+hot)		litre	167+42	167+42
Energy consumption (motor/heating)		kWh	0.55/1.05	0.6
Steam consumption		kg	-	1.6
* Water temperature 15°C cold water and 65°C hot water.				
** Depending on steam pressure.				

Produced according to ISO 9001 and ISO 14001.

Certified with CB certificate for Low Voltage Directive and S-mark according to the Machinery Directive. Protection class IP X4D.

Electrical connections					
Heating alternative	Main voltage		Heating power kW	Total power kW	Recommended fuse A
		Hz			
Electric heated	220-240V 3 -	50/60	19.8/23.0	20.5/23.7	63
	380-415V 3 -	50/60	19.8/23.0	20.5/23.7	35/50
	440V 3 -	60	21.0/23.0	21.7/23.7	35
	480V 3 -	60	22.8/23.0	23.5/23.7	35
	220-230V 3 -	50/60	19.1	19.8	63
	380-400V 3 -	50/60	19.1	19.8	35
Steam or Non heated	220-240V 1 -	50/60	-	2.5	16
	380-480V 1 -	50/60	-	2.5	10

Water and steam connection		W4240H
Water valves	DN	20
Water pressure	kPa	150-400
Capacity at 300 kPa	l/min	60
Drain valve	∅ mm	75
Draining capacity	l/min	170
Steam valve	DN	15
Steam pressure	kPa	300-600
Liquid detergent supplies		5
Floor requirements		
Frequency of the dynamic force	Hz	14.8
Floor load at max extraction	kN	5.2 ± 1.0
Sound levels		
Sound pressure level*		
Wash	dB(A)	<70
Extraction	dB(A)	85
Heat emission		
% of installed power, max		5
Shipping data**		
Weight	net, kg crated, kg	400 448
Shipping volume	m <sup>3</sup>	1.79
Accessories		
Steel base frame		x
Water re-use tank (Clarus Control)		x
Hose kits for water or steam		x
Dimensions in mm		
A Width		1020
B Depth		915
C Height		1445
D		500
E		955
F		1155
G		100
H		1360
I		215
K		1320
L		300
M		380
N		100
O		360
P		510
1	Electrical connections	6
2	Cold water	7
3	Hot water	8
4	Steam connection	9
5	Drain	
		6
		7
		8
		9

\* A-weighted emission sound pressure level at workingstations.

\*\* Average data. Crated weight/shipping volume depends on configuration. Please contact logistics for exact measures.

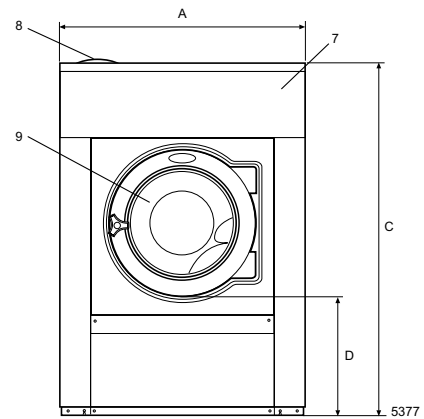

Front

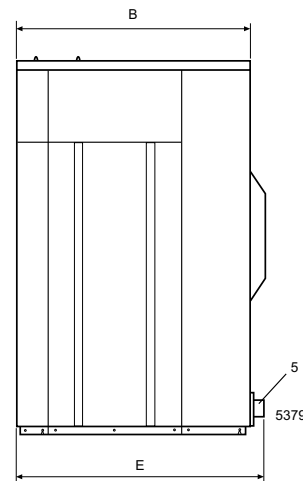

Right side

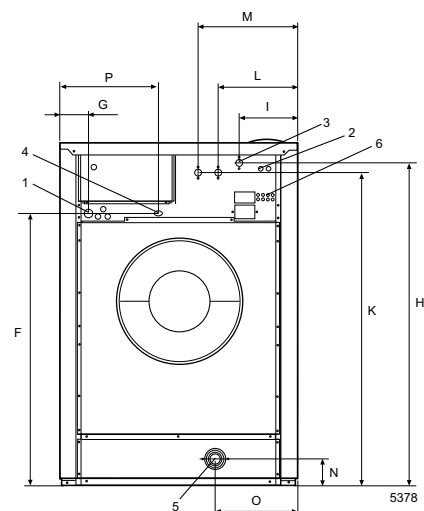

Rear side