

Tumble dryer

T5190

Features and benefits

- **Compass Pro[®] microprocessor offers:**
 - Large display and one control knob for easy program selection
 - Language selection
 - Quick selection and option buttons for the most frequently used drying programs and options
 - Drying program packages optimized for Economy, Care and Time and option buttons for selection of dryness
 - Service program for adjustment of parameters
 - USB connection
- High productivity – 2 full loads per hour
- Low energy consumption for optimal efficiency
- Reversible door hanging for a convenient laundry flow
- Easy access to vital parts from front and rear for simple servicing
- The coin version with Ecopower to avoid over drying of the garments and get a lower energy consumption
- Residual Moisture Control for an accurate drying result and a low energy consumption
- Reversing drum for less tangling of large items



Images shown are a representation of the product only and variations may occur.

Main options

- Stainless steel front
- Stainless steel drum
- Payment: coinmeter with Ecopower, chipcard reader, CP connection
- Stainless steel base frame
- Separate condense system
- Fresh air intake

Main specifications		T5190			
Rated capacity, filling factor 1:18	kg/lb	10.6/23			
filling factor 1:22	kg/lb	8.6/19			
Drum volume	litre	190			
Drum diameter	mm	680			
Heating, electric	kW	6.0/8.0			
gas	BTU/h (kW)	20500/27300 (6.0/8.0)			
Consumption data*		6.0 kW	8.0 kW	Gas 6.0 kW	Gas 8.0 kW
Total time full load	min	35	27	36	29
Energy consumption full load	kWh	3.45	3.53	3.67	3.74
Evaporation	g/min	102	129	106	131
Energy kWh/litre water evaporated	kWh/l	0.92	0.94	-	-

* At rated capacity 100% cotton load at 50% initial moisture dried to 0%.

Produced according to ISO 9001 and ISO 14001.

Certified with CB certificate for Low Voltage Directive and S-mark according to the Machinery Directive. Protection class IP X4D.

Electrical connections					
Heating alternative	Main voltage		Heating power kW	Total power kW	Recommended fuse A
		Hz			
Electric heated	220-240V 1 ~	50/60	6.0/8.0	6.3/8.3	35/50
	220-230V 3 ~	50/60	6.0/8.0	6.3/8.3	20/25
	240V 3 ~	50/60	6.0/8.0	6.3/8.3	16/25
	380-415V 3 ~	50/60	6.0/8.0	6.3/8.3	10/16
	440/480V 3 ~	60	6.0/8.0	6.3/8.3	10/16
	115V 3 ~	60	4.4	4.7	25
Gas heated	220-480V 1/3 ~	50/60	-	0.3	10

Gas and air connections			T5190
Gas		ISO 7/1-R	1/2"
Gas pressure	Natural gas	Pa	2000
		mbar	20
	Propane	Pa	2800-5000
		mbar	30
Air outlet		ø mm	125
Evacuated air	6.0 kW	m ³ /h	270
	8.0 kW		290
Pressure drop	6.0 kW	Max. Pa	380
	8.0 kW		350

Sound levels	
Sound power/pressure level at drying*	
	dB(A) 67/53

Heat emission	
% of installed power, max	15

Shipping data**	
Weight	net, kg 99
Shipping volume	m ³ 0.83

Dimensions in mm	
A Width	721
B(a) Depth (Gas)	778
B(b) Depth (EI)	759
B(c) Depth	684
C Height	1114
D	404
E	45
F	180
G	88
H	113
I	79
J	561

- 1 Operating panel
- 2 Door opening ø 400 mm
- 3 Electrical connection
- 4 Gas connection
- 5 Exhaust connection

* Sound power levels measured according to ISO 60704.

** Average data. Crated weight/shipping volume depends on configuration. Please contact logistics for exact measures.

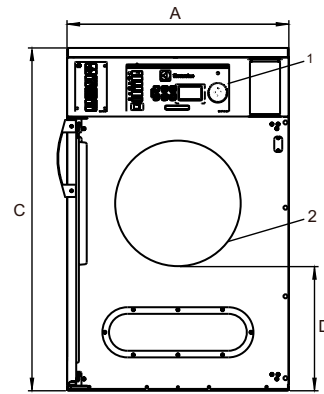

Front

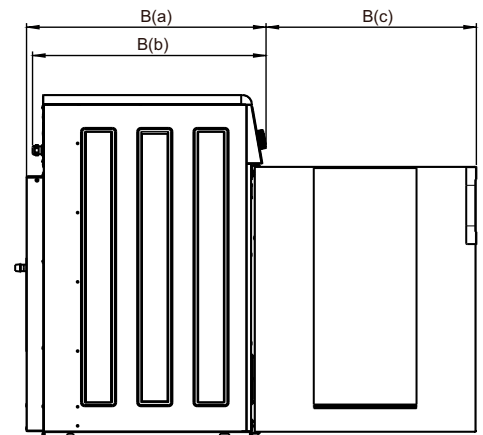

Side view

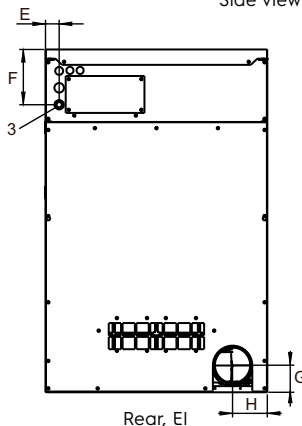

Rear, EI

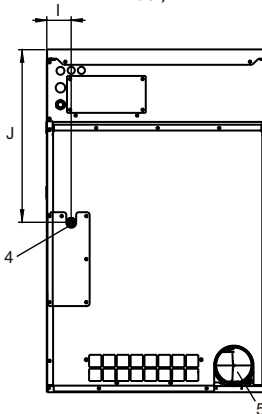

Rear, Gas